

ITEM NO.	P/N	QTY.
1	PFM-9.2 Body	1
2	50-651	2
3	50-462	1
4	50-560	1
5	35-936	2
6	50-661	1
7	50-570	1
8	50-566	1
9	50-658	2
10	50-565	1
11	50-564	1
12	37-494	1
13	37-493	1
14	37-905	1
15	35-229	2
16	36-020	2
17	50-530	1
18	50-410	1
19	50-100	1
20	35-411	3
21	50-041	1
22	50-625	1
23	35-717	8
24	35-236	7
25	50-424	1
26	35-160	2
27	37-492	1
28	36-113	1
29	50-033	1
30	37-806	3
31	35-923	3
32	37-808	3
33	37-004	2
34	37-078	2
35	37-079	2
36	50-567	1
37	50-569	1
38	50-436	1
39	35-412	2
40	37-725	1
41	50-655	1
42	35-239	2
43	50-447	1

50-920

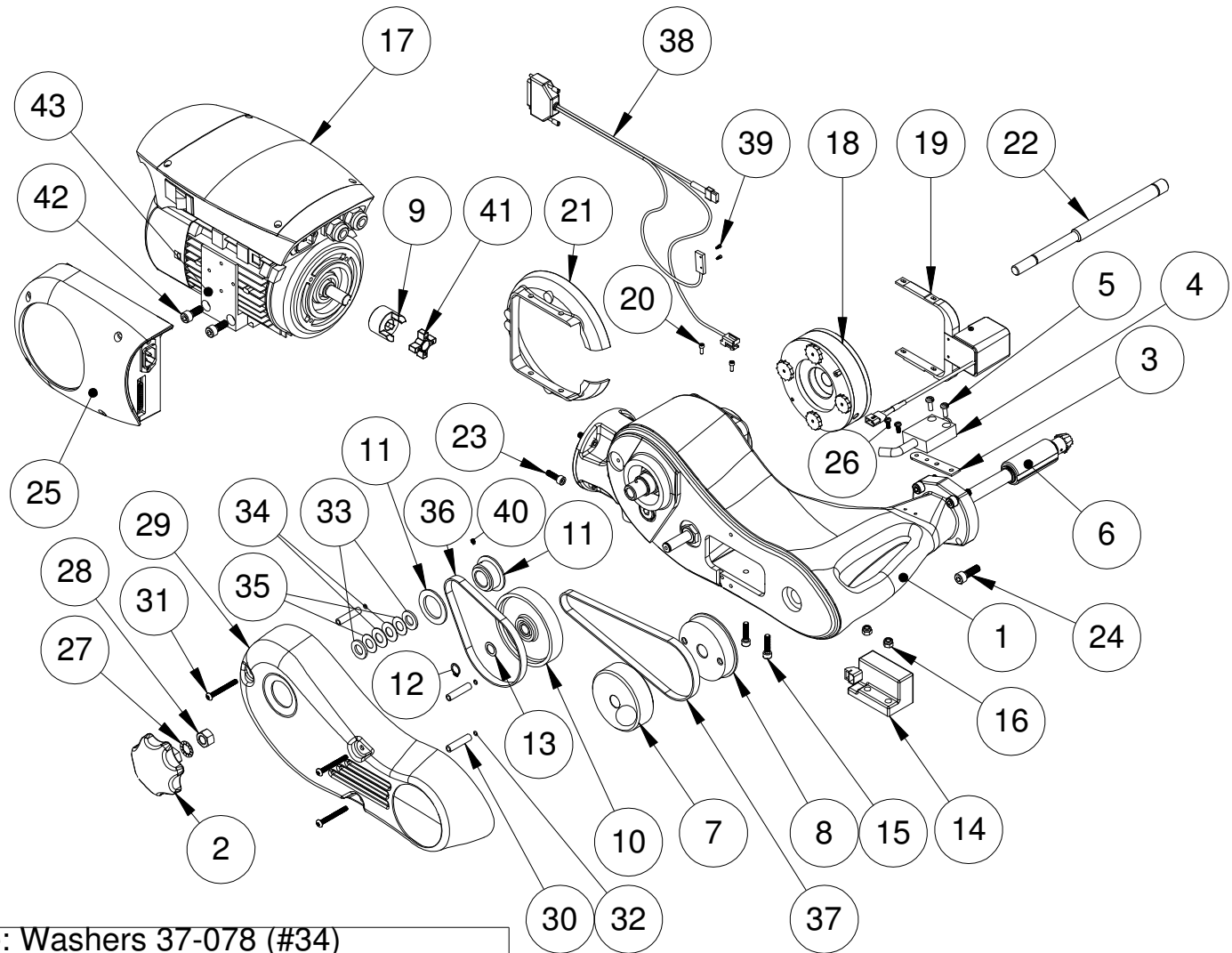

Note: Washers 37-078 (#34) must be cupped like this: ((
 50-658 is the entire coupling assembly.
 50-530 is 1hp 120V 60Hz
Not shown:
 Motor key: 37-445
 Cord clamp: 37-628
 Keypad: 50-409

50-139 Bevel Gearbox Assembly

ITEM NO.	PART NUMBER	QTY.
1	37-056	2
2	35-928	1
3	50-021	1
4	37-057	2
5	37-927	4
6	50-014	1
7	50-016	1
8	50-039	1

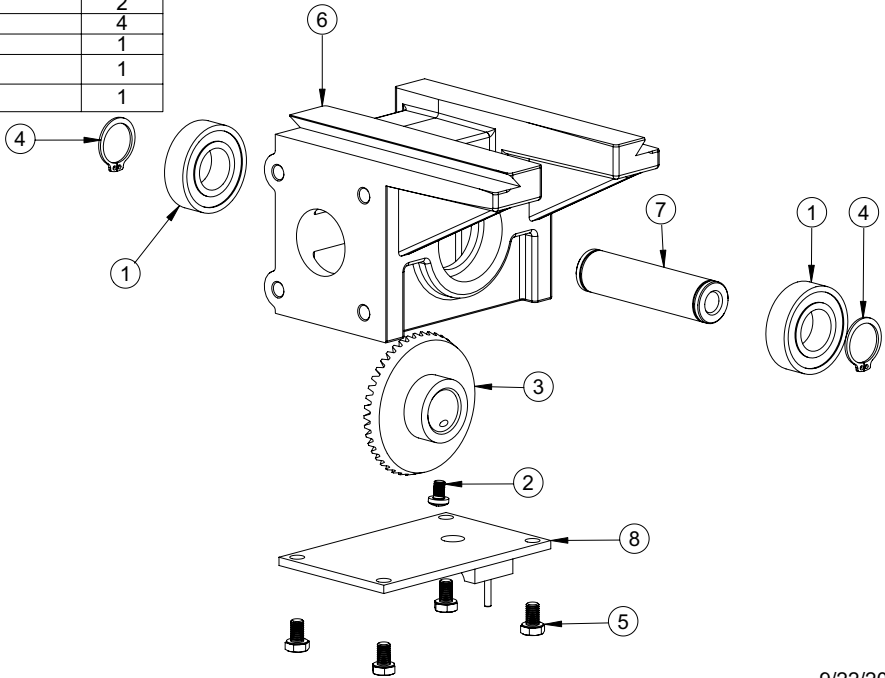

9/22/2006

50-220 Cutting Head Assembly

ITEM NO.	PART NUMBER	QTY
1	50-293	1
2	50-361	1
3	50-362	1
4	50-252	1
5	50-053	1
6	50-250	1
7	37-473	1
8	50-253	1
9	50-254	1
10	50-249	1
11	37-459	1
12	50-098	2
13	37-077	4
14	35-259	1
15	36-002	2
16	37-082	2
17	37-003	3

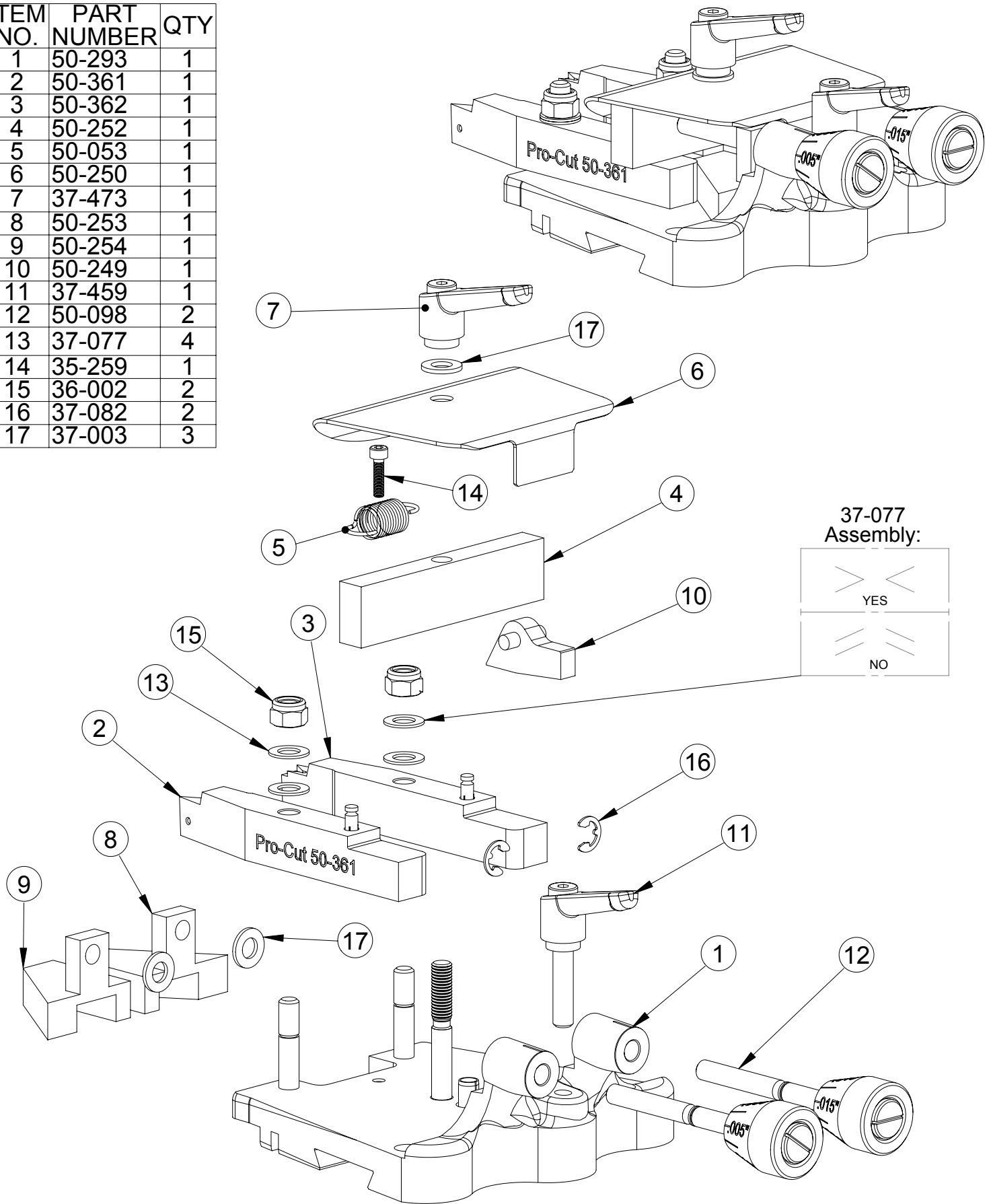

50-143 Gearbox, Slide and Cutting Head Assembly

ITEM NO.	PART NUMBER	QTY.
1	50-139	1
2	50-034	1
3	50-226	1
4	50-463	1
5	35-236	2

