



Classification:
BR09-002a

Reference:
ITB09-037a

Date:
September 17, 2009

G COUPE AND SEDAN; BRAKE JUDDER

This bulletin has been amended. The NMC MODEL CODE / PISTON TYPE CHART has been revised.
Please discard previous versions of this bulletin.

- APPLIED VEHICLES:** 2007-2009 G Sedan (V36)
2008-2009 G Coupe (CV36)
- APPLIED VINS:** 2007-2008 G Sedan - ALL
2008 G Coupe - ALL
2009 G Coupe vehicles built between:
JNKCV(*)4(**)9M 600008 and JNKCV(*)4(**)9M 652073
2009 G Sedan vehicles built between:
JNKCV(*)1(**)9M 010111 and JNKCV(*)1(**)9M 051571
or
JNKCV(*)1(**)9M 300016 and JNKCV(*)1(**)9M 353912
- APPLIED DATES:** Vehicles built before: October 6, 2008

IF YOU CONFIRM:

While braking, especially when braking at highway speeds:

- the steering wheel shakes and/or
- the body vibrates and/or
- the brake pedal pulsates (also known as "Brake Judder")

IMPORTANT NOTES:

- If incident occurs when cruising or coasting (not braking) it is not "Brake Judder," and may be tire/wheel related. Refer to ASIST for further diagnostic assistance.
- DO NOT CONFUSE "Brake Judder" with the rapid consistent-speed pedal pulsation that may be felt and only occurs when ABS is activated during hard braking or on slippery road surfaces. In contrast, the pedal pulsation of "Brake Judder" may occur with light to moderate braking experienced during normal driving conditions, and the pulsation rate will vary (faster or slower) with vehicle speed.
- The purpose of "ACTIONS" (on page 2) is to give you a quick idea of the work you will be performing. You MUST closely follow the entire Service Procedure as it contains information that is essential to successfully completing this repair.

Infiniti Bulletins are intended for use by qualified technicians, not 'do-it-yourselfers'. Qualified technicians are properly trained individuals who have the equipment, tools, safety instruction, and know-how to do a job properly and safely. NOTE: If you believe that a described condition may apply to a particular vehicle, DO NOT assume that it does. See your Infiniti dealer to determine if this applies to your vehicle.

ACTIONS:

1. Identify the brake system by NMC Model Code or visual inspection.
2. Remove the front brake caliper and rotor.
3. Install the new front brake backing plate (splash guard assembly).
4. Inspect the front brake rotor to determine if resurfacing is possible or if replacement is necessary.
5. Reinstall the front brake caliper.
6. Inspect the brake pads and install the new brake pad kit and new hardware kit if replacement is necessary.
7. Perform procedure on the other side of the vehicle.

IDENTIFY BRAKE SYSTEM BY NMC MODEL CODE

1. Log onto SERVICE-COMM and locate the vehicle's 5-digit "NMC MODEL" code (see Figure 1).
 - Right down the NMC MODEL code.
 - This number will be compared to the **NMC MODEL CODE/PISTON TYPE CHART** on page 5 to determine which brake system you are working with and which parts you will use.

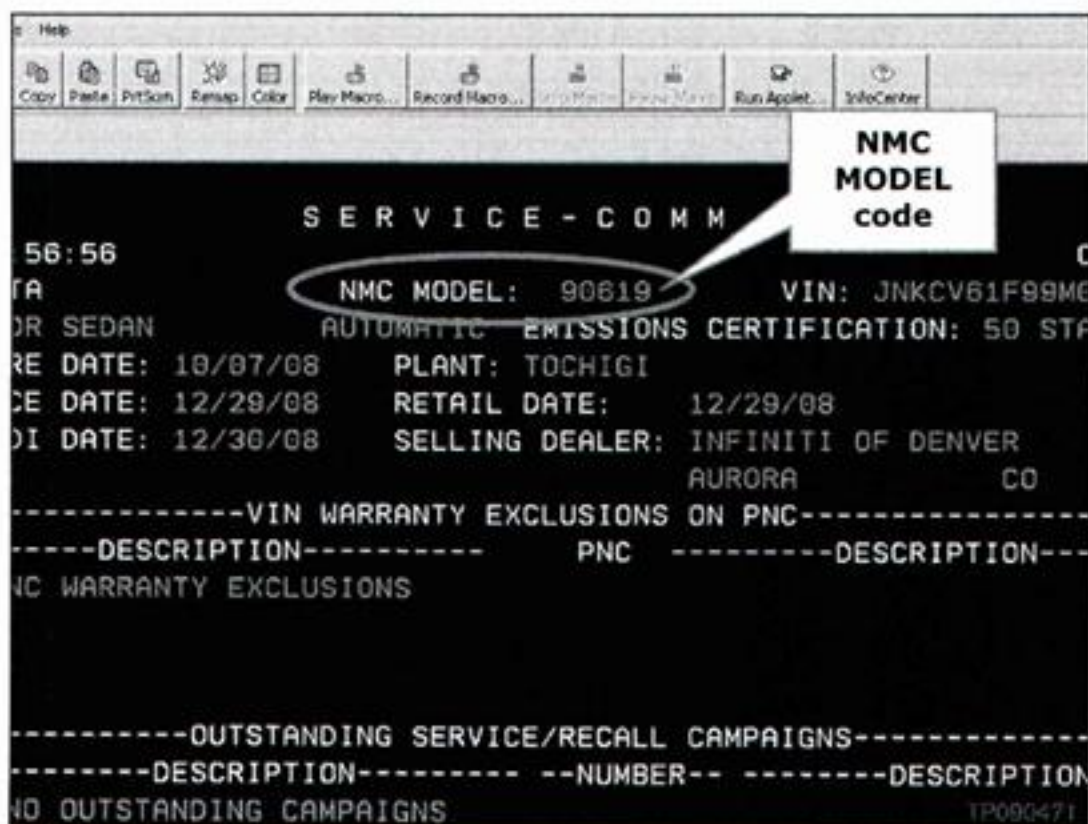
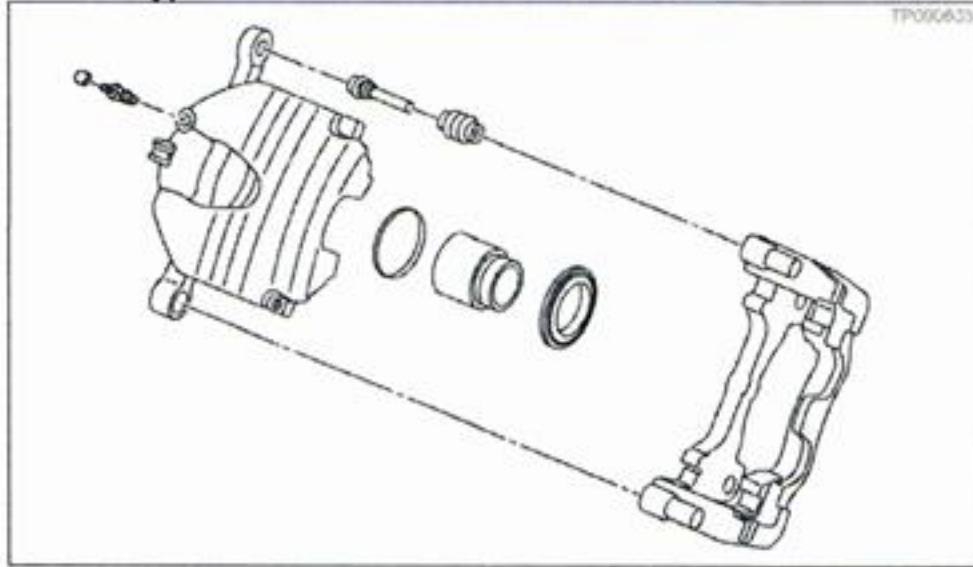

Figure 1

IDENTIFY BRAKE SYSTEM BY VISUAL INSPECTION

This information will be compared to the **NMC MODEL CODE/PISTON TYPE CHART** on page 5 to determine which brake system you are working with and which parts you will use.

1-Piston Type



2-Piston Type

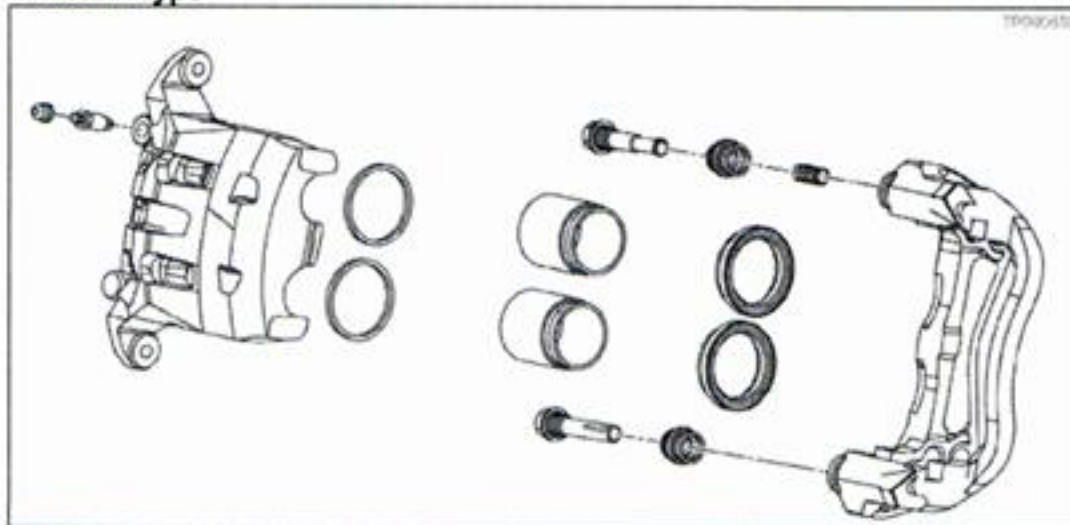

4-Piston Type

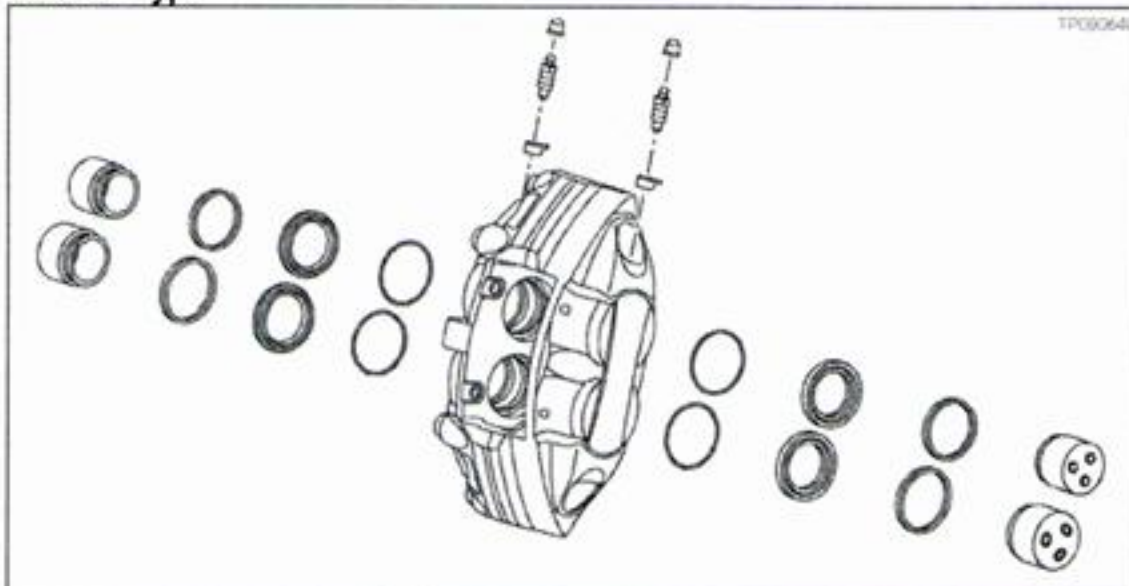

SERVICE PROCEDURE

1. Remove the front brake caliper assembly and rotor.
 - Refer to the BR section in the applicable Electronic Service Manual for removal information.
2. Install the new front brake backing plate (splash guard assembly-RH or LH) listed in the Parts Information section.
3. Inspect the front brake rotor to determine if brake rotor resurfacing is possible or if replacement is necessary.
 - Refer to the BR section in the applicable Electronic Service Manual for brake rotor inspection information.
4. If rotor resurfacing is possible, make sure to use the ProCut PFM Series on-car brake lathe.
5. If necessary, replace both rotors with the new rotor listed in the Parts Information section. Do not replace only one rotor.
6. Reinstall the brake caliper assembly.
7. Inspect the brake pads and install the new brake pad kit and the new hardware kit listed in the Parts Information section if replacement is necessary.
 - Refer to the BR section in the applicable Electronic Service Manual for brake pad inspection and installation information.
8. Perform this procedure on the other side of the vehicle.

CLAIMS INFORMATION

Submit a Primary Part (PP) type line claim using the following claims coding:

DESCRIPTION	PFP	OP CODE	SYM	DIA	FRT
RPL Front Brake Splash Shield & Grind Rotor - (2WD, Both Sides)	(1)	PX43AA	EA	43	2.3
RPL Front Brake Splash Shield & Grind Rotor - (4WD, Both Sides)	(1)	PX45AA	EA	43	2.4
RPL Front Brake Splash Shield & Rotor - (2WD, Both Sides)	(1)	PX47AA	EA	43	1.5
RPL Front Brake Splash Shield & Rotor - (4WD, Both Sides)	(1)	PX49AA	EA	43	2.5

(1) Refer to the electronic parts catalog (FAST or equivalent) and use the appropriate Guard Assy-Splash, Fr Brake part number as the PFP.

PARTS INFORMATION

DESCRIPTION	PART #	QUANTITY
Guard Assy-Splash, Fr Brake, RH	See NMC MODEL CODE/PISTON TYPE CHART , below	1
Guard Assy-Splash, Fr Brake, LH		1
Hardware Kit-Front Disc Brake Pad		1 (if needed)
Pad Kit-Disc Brake		1 (if needed)
Rotor-Disc Brake, Front		2 (if needed)

NMC MODEL CODE / PISTON TYPE CHART

NMC MODEL CODE	PISTON TYPE	Splash Guard Assy P/N	Brake Pad Hardware Kit P/N	Brake Pad Kit P/N	Front Rotor
90417	2 Piston	41151-EJ70A (Right) 41161-EJ70A (Left)	41080-AR026	41060-EG090 (vehicles produced 8/06 - 8/07) or D1060-EG51A (vehicles produced 8/07 and later)	40206-EG000
90418					
90517					
90518					
90617					
90618					
99419					
90717	1 Piston	41151-1BF0A (Right) 41161-1BF0A (Left)	D1080-JK00B	D1060-JK00B	40206-JK600
90767					
90768					
99118					
99119					
99219					
99218	4 Piston	41151-JL30A (Right) 41161-JL30A (Left)	D1080-JL00A	D1060-JL00B	40206-JL00A
99368					
99369					